

Research Migration Project

<https://esim.fossee.in/research-migration-project>



The Research Migration Project is an initiative of FOSSEE, IIT Bombay that promotes the use of eSim for reproducing published research circuits originally implemented using proprietary simulation tools. The objective is to migrate these validated designs to eSim to build an open source resource database.

Name of the participant : *(Trisha Das)

Affiliation / Institution : *(Department of Electronics & Communication Engineering, NIT Silchar, Silchar, Assam, India.)

Title of the circuit : *(Implementation of a Nonlinear Square Root Computational Circuit in eSim using 180nm Library)

Theory/Description : *(The circuit is an Analog Computational Block that leverages the Square-Law characteristic of a MOSFET operating in the Saturation Region. In this configuration, the MOSFET is placed in the feedback loop of an Operational Amplifier to perform a nonlinear transfer function.

Principle of Operation

The core principle is the conversion of an input voltage into a current, which is then shaped by the MOSFET's quadratic I_D/V_{GS} relationship. By placing the MOSFET in the feedback path, the Op-Amp forces the output voltage to become the inverse function of the feedback element's characteristic—resulting in a Square Root response.

Key Components

- **Operational Amplifier (LM741):** Acts as a high-gain error amplifier, maintaining a Virtual Ground at the inverting terminal.
- **NMOS (180nm):** The nonlinear feedback element. It must be biased in saturation .
- **Input Resistor (R_{in}):** Converts the input voltage (V_{in}) into a proportional linear current (I_{in}).
- **Compensation Capacitor (C_{fb}):** Essential for stability; it reduces loop gain at high frequencies to prevent oscillations.

Overall Function

1. **Current Summing:** The Op-Amp maintains the inverting node at 0V. Thus, $I_{in} = V_{in}/R_1$.
2. **Feedback Balancing:** To maintain equilibrium, the Op-Amp adjusts V_{out} such that the MOSFET Drain current I_D exactly equals I_{in} .

3.Result: Solving for V_{out} yields a value proportional to square root of V_{in} , effectively performing a real-time hardware square-root calculation.

Reason to reproduce with eSim : (Open-Source Integration: eSim leverages Ngspice, allowing for the use of industry-standard 180nm SCL MOSFET libraries. This ensures that the nonlinear square-law behavior observed in simulation is grounded in real-world semiconductor parameters.

Educational Value: The design demonstrates core VLSI and analog concepts—such as Virtual Ground, Feedback Theory, and Translinearity—in a visual, interactive format that is easier to grasp than pure mathematical modeling.

Ease of Verification: eSim's integrated plotting tools (like Ngspice and Python-based plotting) allow for immediate side-by-side comparison of DC Transfer Curves and Transient Waveforms, making it simple to verify that the output correctly follows a square root of x relationship.

Low Barrier to Reproduction: Unlike proprietary CAD tools, eSim's open-source nature means the project can be shared and reproduced globally without licensing costs, fostering collaborative improvement and "what-if" experimentation with different W/L ratios or resistor values.

Design Optimization: The platform allows for rapid iteration—such as adding a compensation capacitor to fix transient oscillations—providing a safe and efficient sandbox for learning stability analysis before moving to physical hardware.

.)

Expected Outcome/outputs : * (1. DC Analysis Expectations

The simulation should yield a nonlinear transfer characteristic curve where V_{out} is a function of square root of V_{in} .

- **Working Behavior:** As V_{in} increases linearly (e.g., 0V to 5V), the output will stay at 0V until the input current overcomes the MOSFET threshold (V_{th}). Once active, the output will follow a downward parabolic path.
- **Validation:** Measure specific points on the curve. If the input is increased by a factor of 4, the "active" portion of the output voltage (excluding the V_{th} offset) should approximately double. This confirms the mathematical square-law relationship.

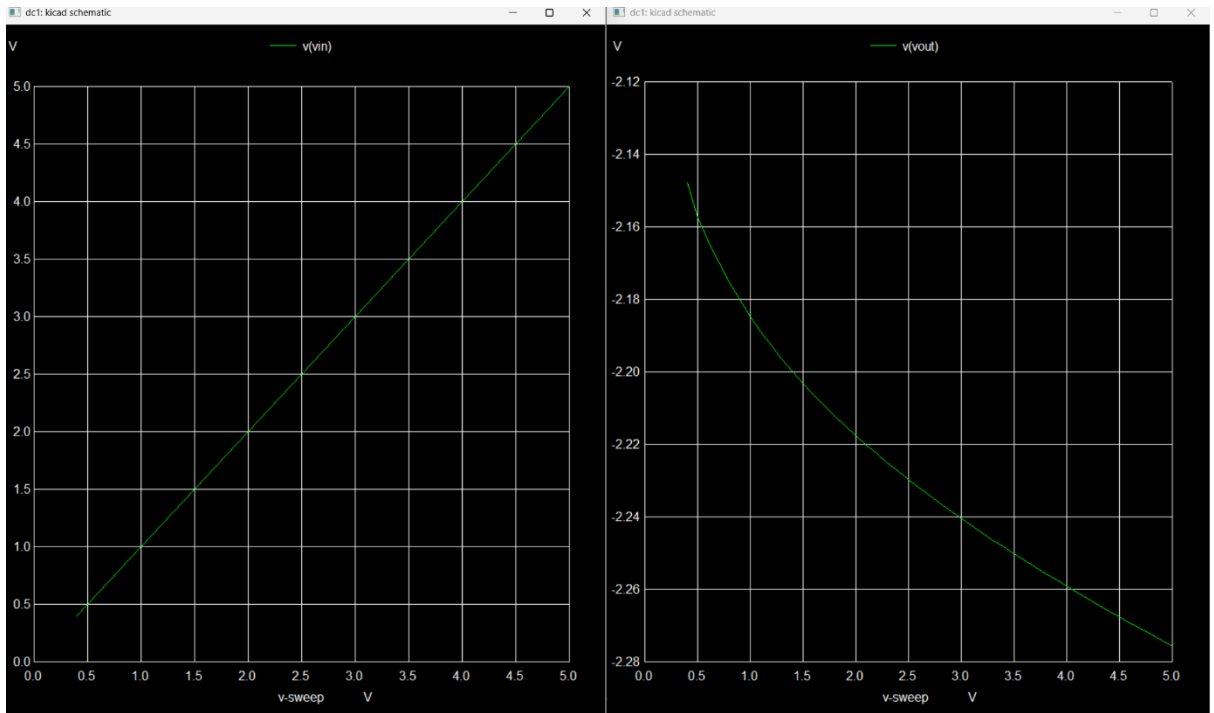

2. Transient Analysis Expectations

The simulation should show the circuit's real-time response to time-varying signals, such as a sine wave.

- **Working Behavior:** With a positive-offset sine wave at the input, the output will be an inverted sine wave (due to the inverting configuration). Because of the square root function, the output peaks will appear "compressed" or flatter compared to the input peaks.
- **Validation:** Ensure the output is stable and free of high-frequency oscillations (verified by the compensation capacitor). Performance is validated by checking the phase shift 180 degree and ensuring V_{out} remains within the linear range (e.g., -3V to -5.5V) without clipping at the supply rails.

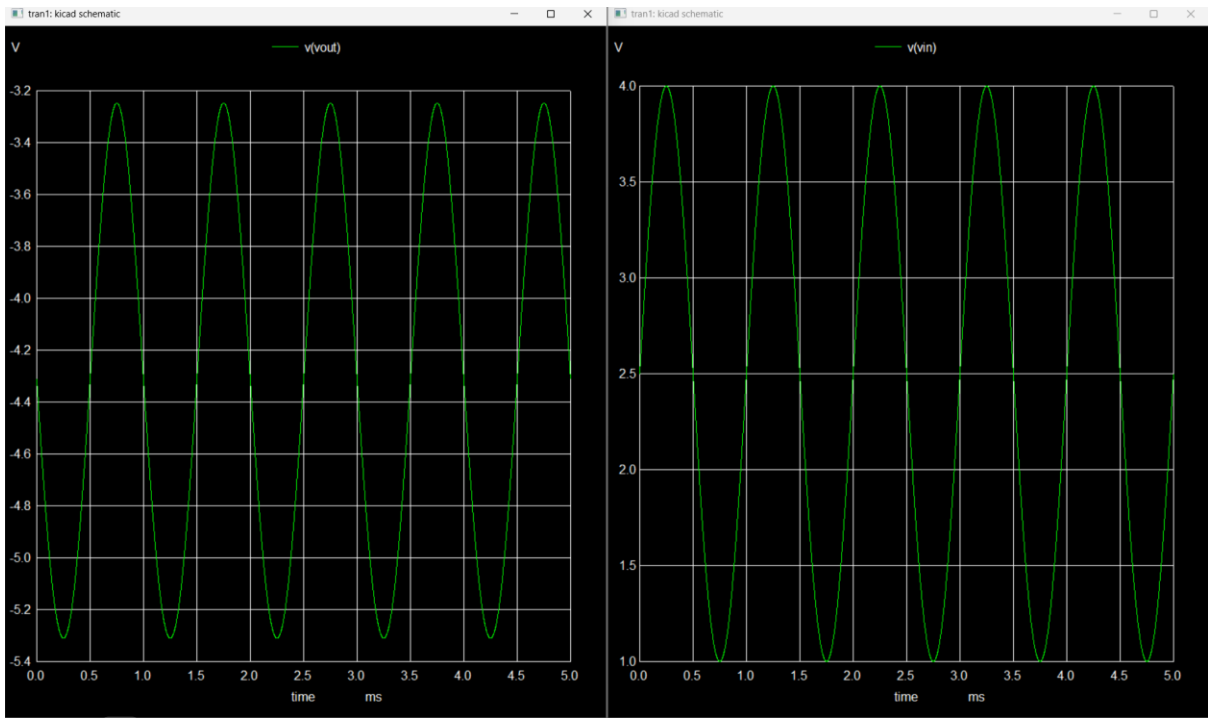

)

Circuit Diagram(s) : *(

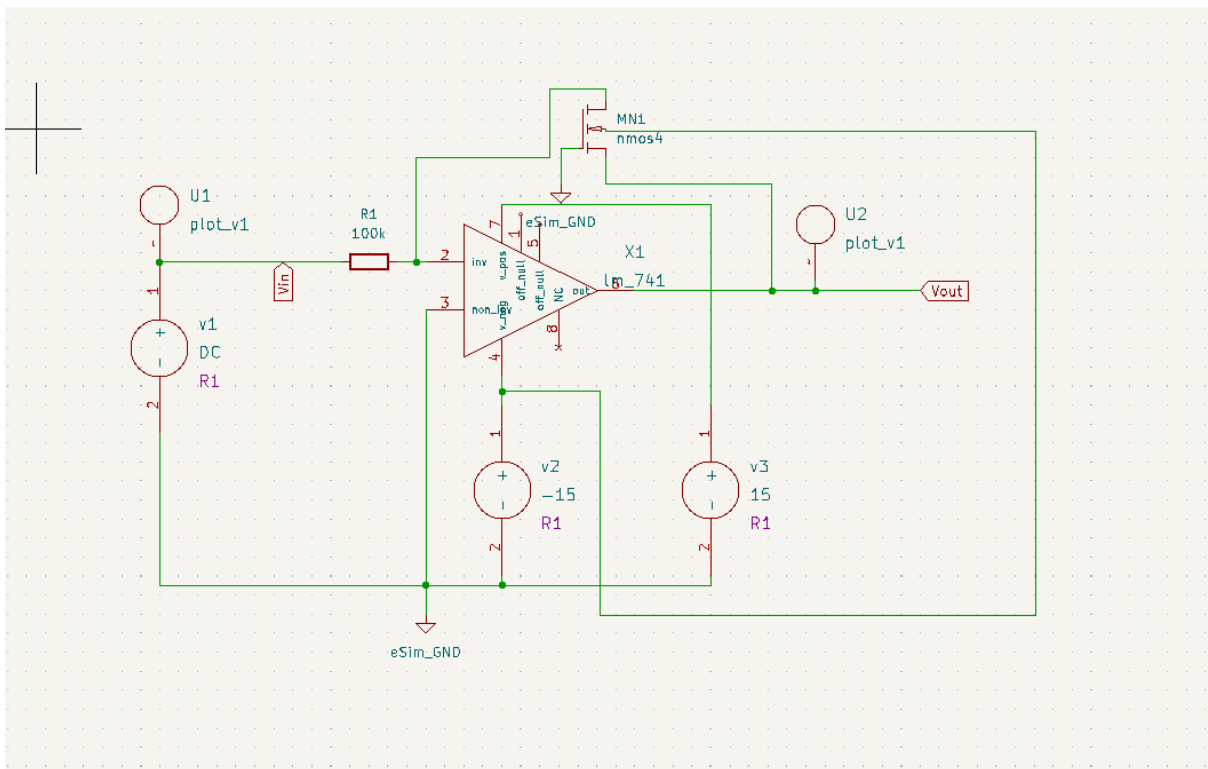

circuit for dc analysis

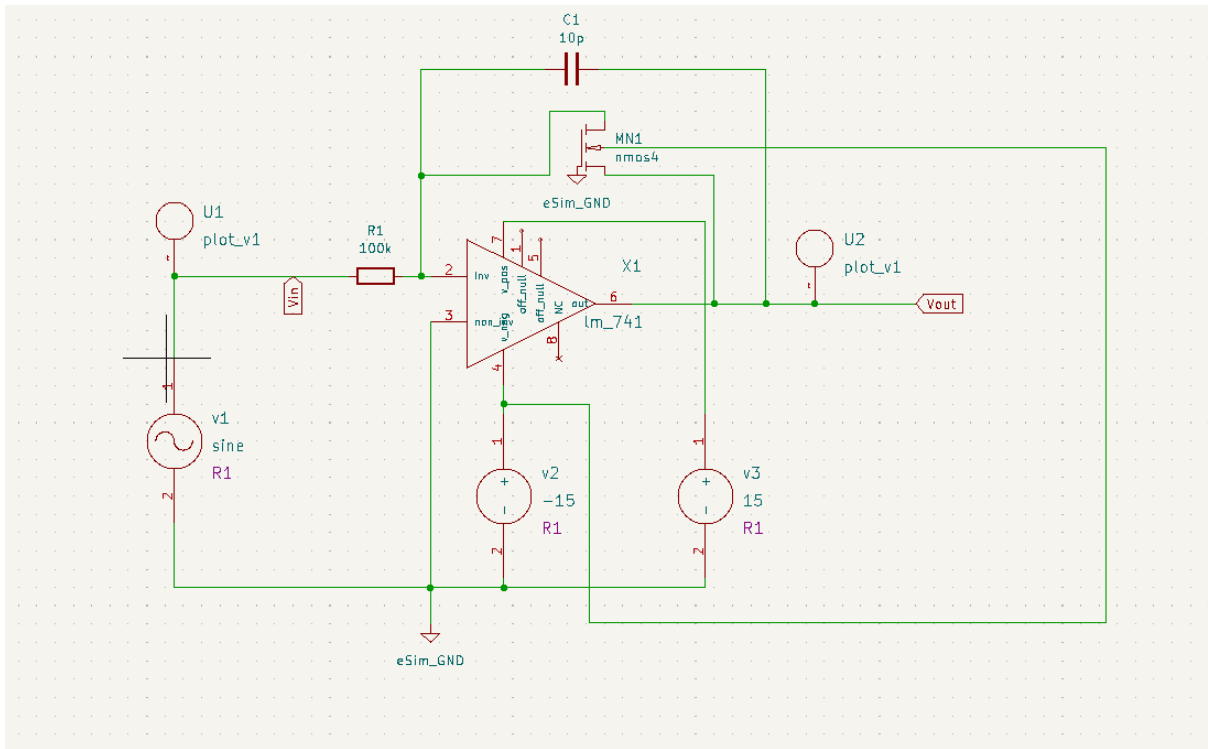

Circuit for ac analysis

Expected Results (Input, Output waveforms and/or Multimeter readings) : *(

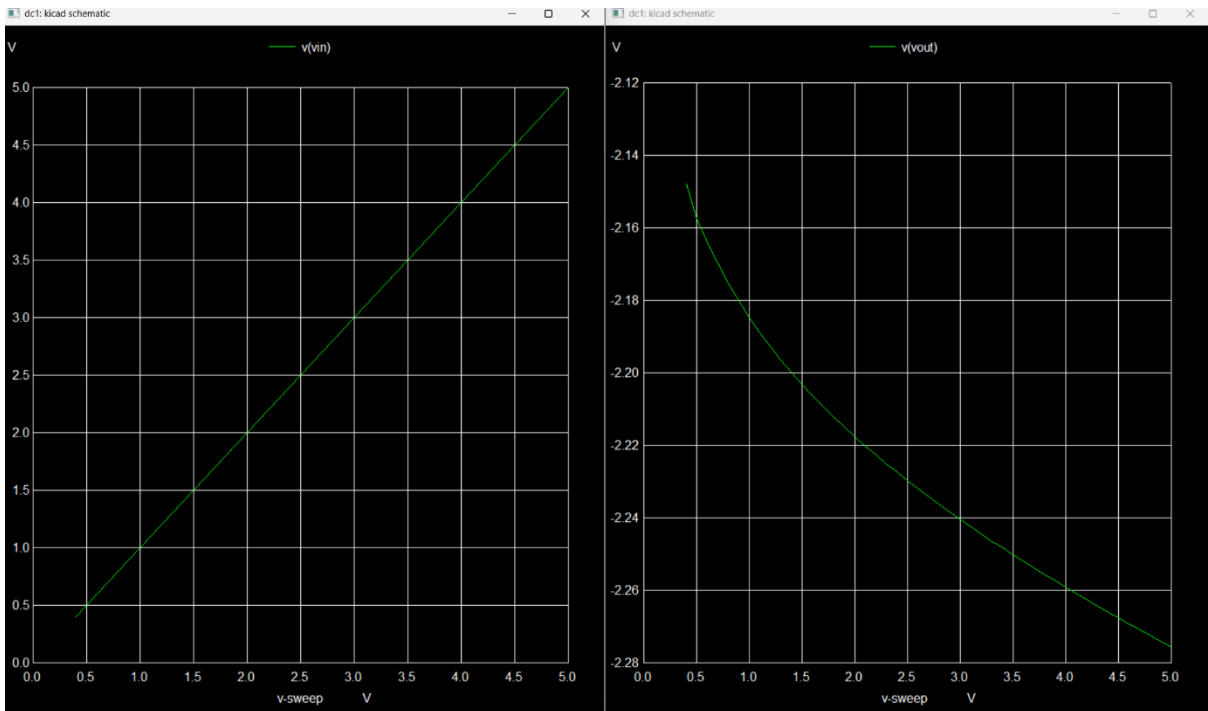

Dc analysis output

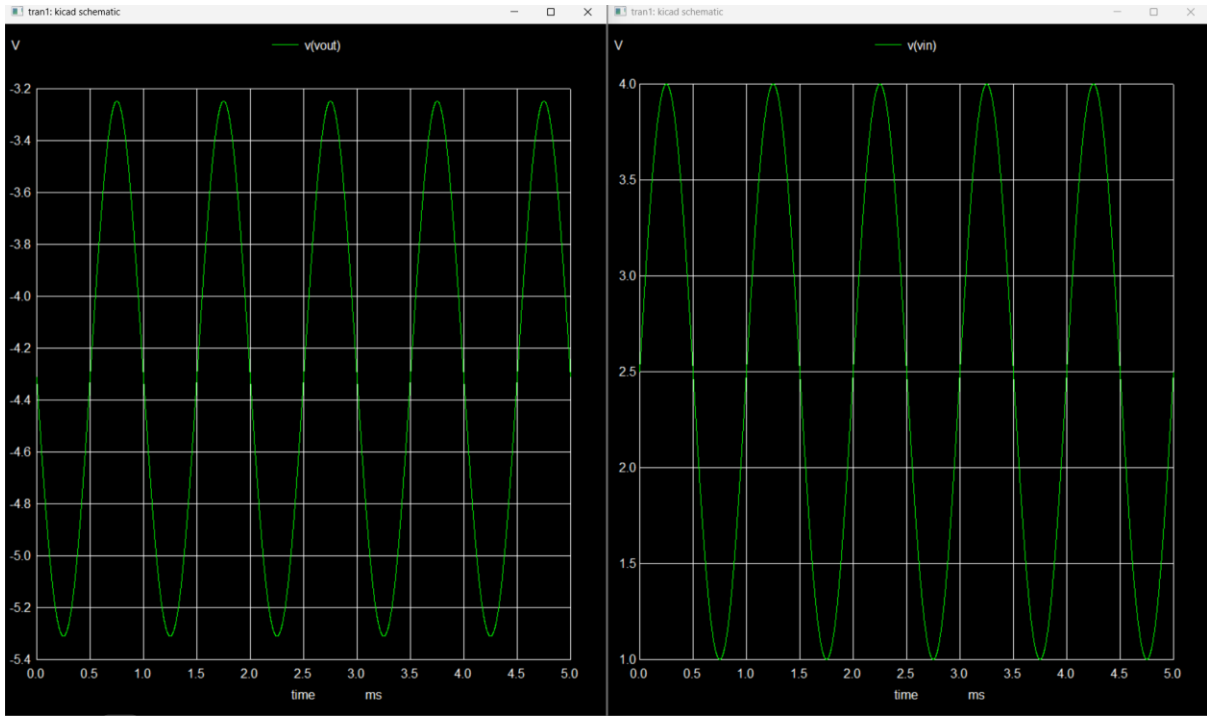

Ac analysis output

)

Research Paper/Journal/etc. : *(

Title : (A Simple Square Rooting Circuit Based on Operational Amplifiers (OPAMPs)

)

Author : (Kannappan Selvam & S.Latha)

Link :

(https://www.researchgate.net/publication/346751971_A_Simple_Square_Rooting_Circuit_Based_on_Operational_Amplifiers_OPAMPs)

Note: Fields marked with an asterisk (*) are mandatory and must be filled for successful submission.