

Research Migration Project

<https://esim.fossee.in/research-migration-project>



The Research Migration Project is an initiative of FOSSEE, IIT Bombay that promotes the use of eSim for reproducing published research circuits originally implemented using proprietary simulation tools. The objective is to migrate these validated designs to eSim to build an open source resource database.

Name of the participant : Ruthu Rani Peddagopu

Affiliation / Institution : Rajiv Gandhi University of Knowledge Technologies , Nuzvid

Title of the circuit : Design and Simulation of Multi-Stage RC Low Pass Filter for Signal Conditioning Applications

Theory/Description : A low pass filter is an analog circuit that allows low-frequency signals to pass while attenuating high-frequency noise. A basic RC low pass filter consists of a resistor and capacitor, where the output is taken across the capacitor. The cutoff frequency is determined by the RC time constant. In this project, a multi-stage RC low pass filter is designed by cascading two RC stages to achieve sharper roll-off and improved noise attenuation. This design is widely used in communication systems and signal conditioning applications.

Reason to reproduce with eSim : This circuit is selected to demonstrate the effectiveness of open-source tools like eSim in analyzing analog filter designs. Reproducing this circuit in eSim helps validate theoretical results, enables easy modification of parameters, and provides an educational platform for understanding filter behavior without relying on proprietary software.

Expected Outcome/outputs : The circuit is expected to attenuate high-frequency components while allowing low-frequency signals to pass. The output waveform will show a smoother version of the input signal with reduced noise. The cutoff frequency and attenuation characteristics will be verified through simulation.

Circuit Diagram(s) :

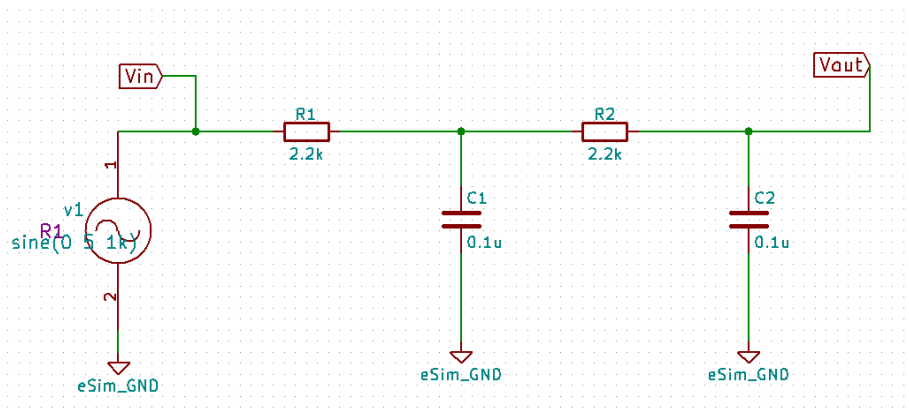

Block Diagram (s) :

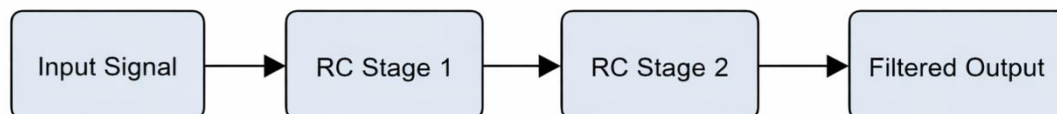

Expected Results (Input, Output waveforms and/or Multimeter readings) :

- Input: Sine wave (10 Vp-p)
- Output: Attenuated sine wave with reduced amplitude
- High-frequency signals are significantly reduced
- Output waveform is smoother than input
- Voltage levels confirm filtering action

Research Paper/Journal/etc. :

Title : A CMOS Active-RC Low-Pass Filter With Simultaneously Tunable High- and Low-Cutoff Frequencies for IEEE 802.22 Applications

Author : Hyunchol Shin, Youngcho Kim

journal : IEEE Transactions on Circuits and Systems II

Link : <https://ieeexplore.ieee.org/document/5438768>

Source/Reference(s) :

- Electronics Tutorials – Low Pass Filter
 - Analog Circuits textbooks
-