

Research Migration Project



<https://esim.fossee.in/research-migration-project>

Name of the participant: Radha Ramdas Shinde

Affiliation / Institution : Department of Electronic And Telecommunication Engineering, A.C.Patil College Of Engineering, Navi Mumbai, Maharashtra, India.

Title of the circuit :

Design and Simulation of a Digital Dice Using CD4017 Decade Counter

Theory/Description :

The proposed project focuses on the design and simulation of a Digital Dice circuit using the CD4017 decade counter IC. The CD4017 is a CMOS-based counter that produces sequential high outputs in response to clock pulses. A clock source is applied to the clock input of the IC, causing the outputs to activate one after another. Selected outputs are utilized to represent dice numbers from one to six. The circuit demonstrates the practical application of sequential logic, counters, and clock-controlled digital systems.

Reason to reproduce with eSim :

Reproducing this circuit using eSim supports the objective of research migration to an open-source EDA platform. The circuit employs standard digital components, making it suitable for simulation using Ngspice. Implementing this project in eSim enhances accessibility for students, promotes open-source learning, and enables verification of digital counter behavior without dependency on proprietary tools.

Expected Outcome/outputs :

When the circuit is simulated in eSim, the CD4017 decade counter generates sequential HIGH outputs in response to clock pulses. Each output remains HIGH for one clock interval while the others stay LOW, representing dice

numbers from one to six. The correct operation of the circuit is validated by observing the output voltage waveforms in Ngspice, which show logic level transitions between LOW and HIGH. The sequential nature of the outputs confirms proper clocking, counting, and reset functionality of the digital dice circuit.

Circuit Diagram(s) :

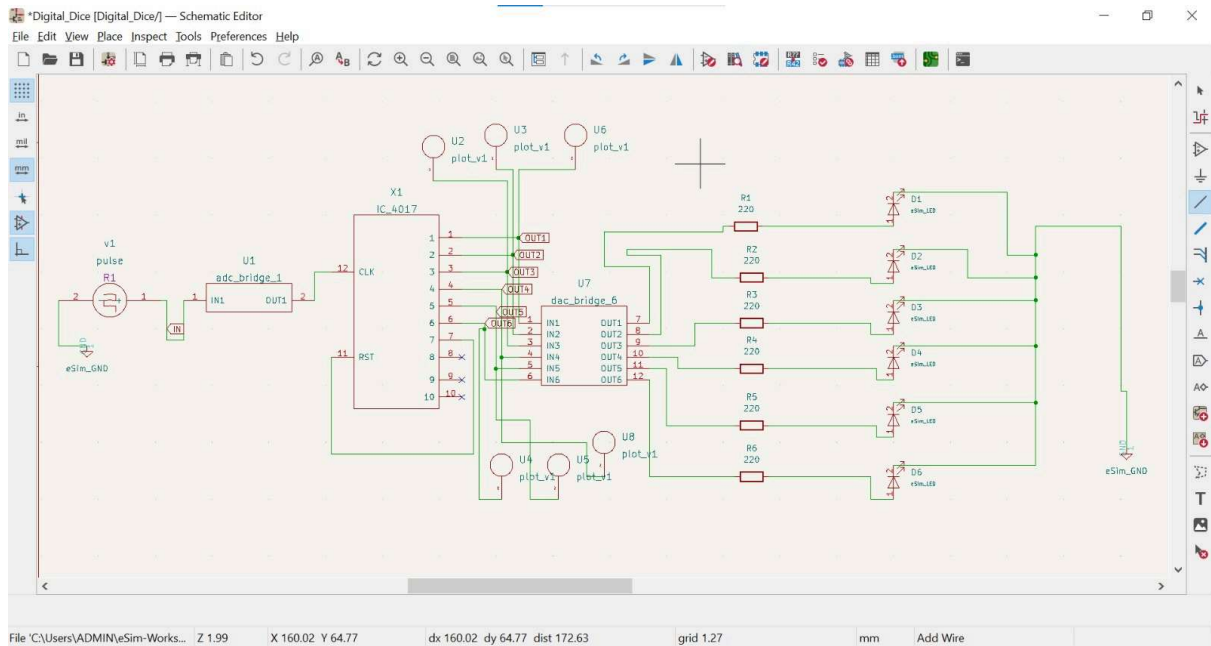

Block Diagram (s) :

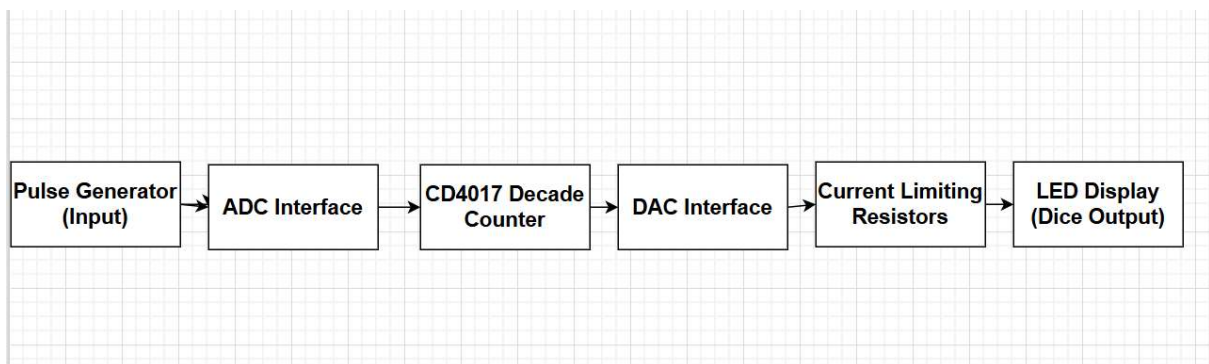

The pulse generator produces clock pulses which are conditioned using an ADC interface and applied to the CD4017 decade counter. The CD4017 sequentially activates its outputs, and these signals are processed through a DAC interface to drive the LEDs via current-limiting resistors. The illuminated LED pattern represents dice numbers ranging from one to six.

Expected Results (Input, Output waveforms and/or Multimeter readings) :

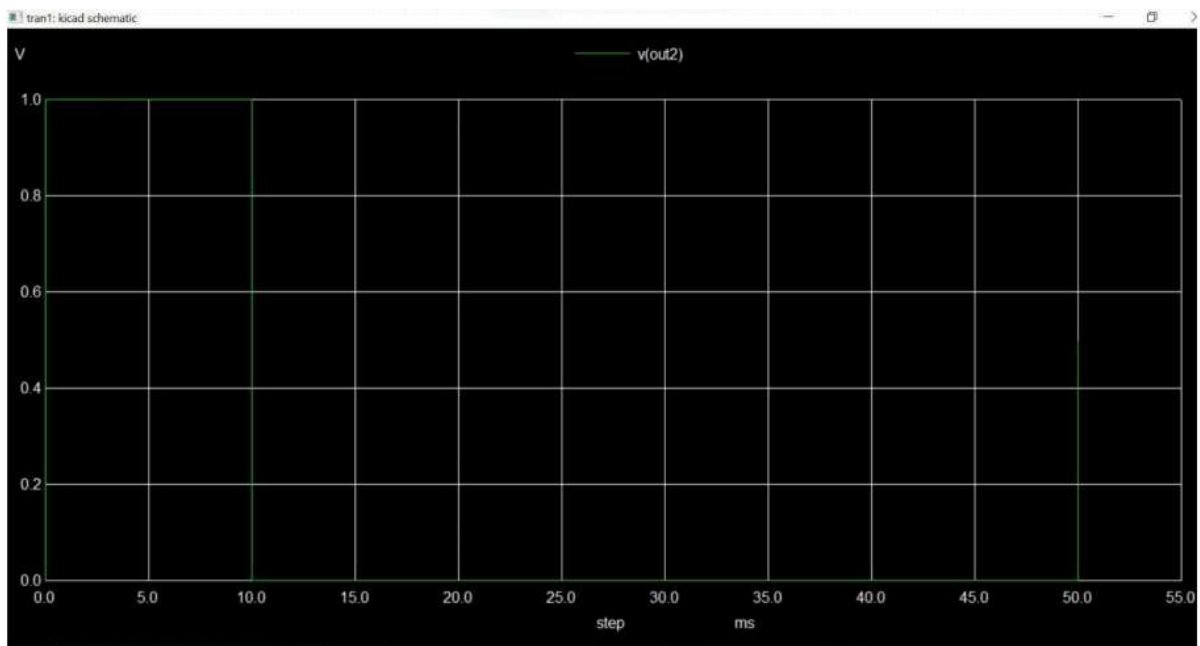
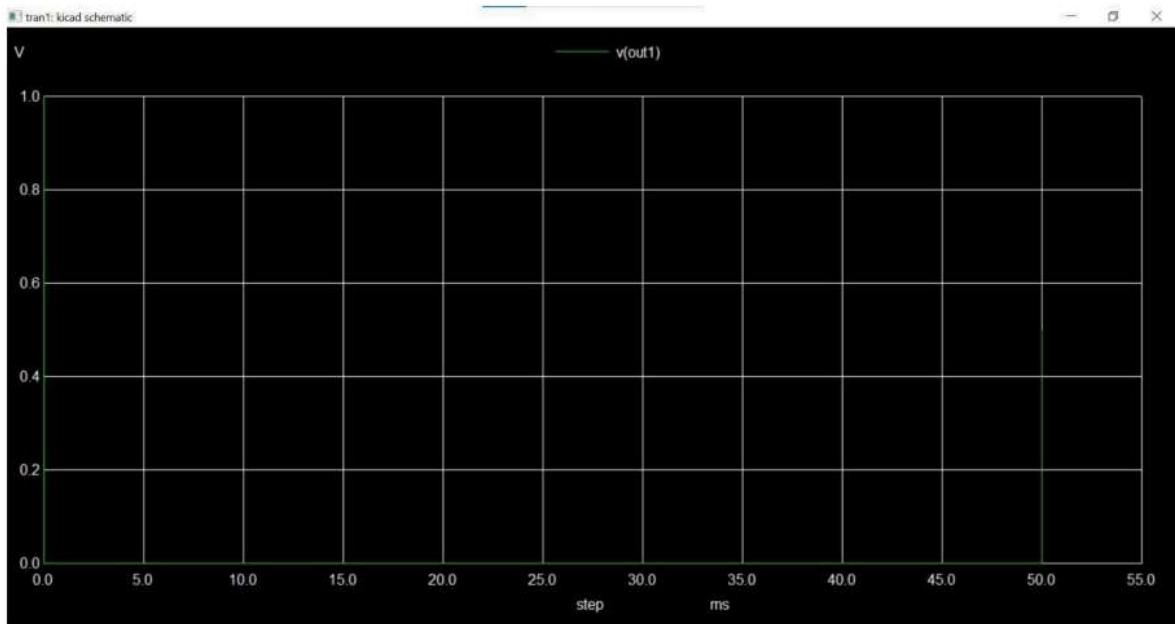

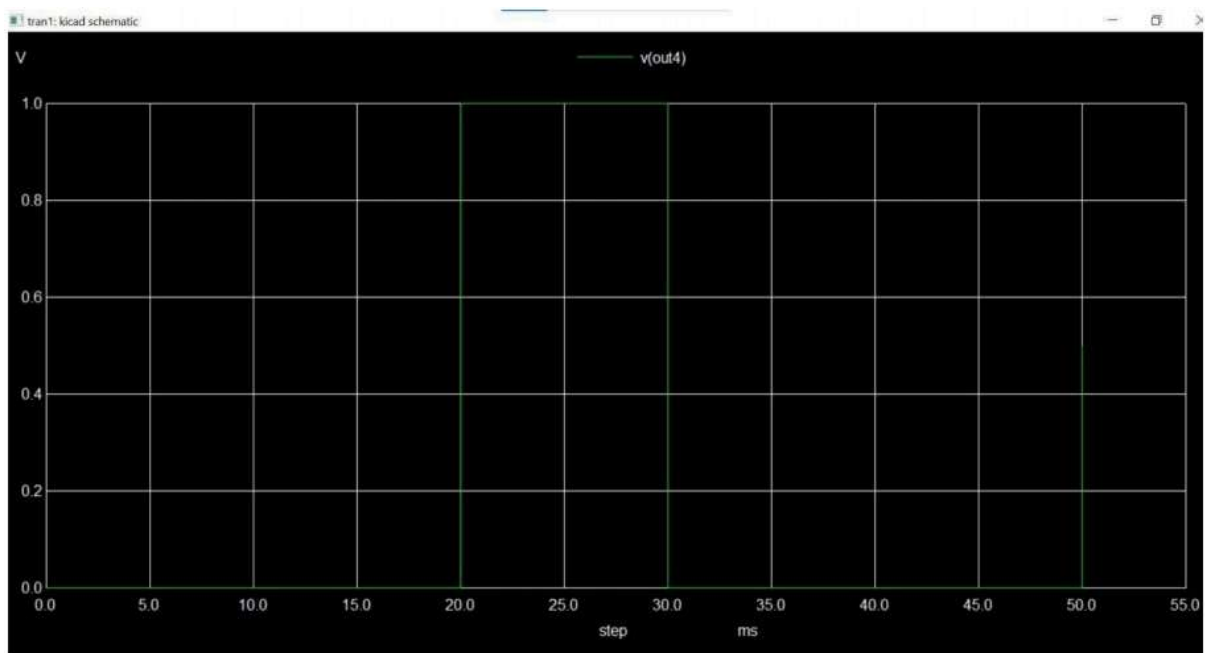
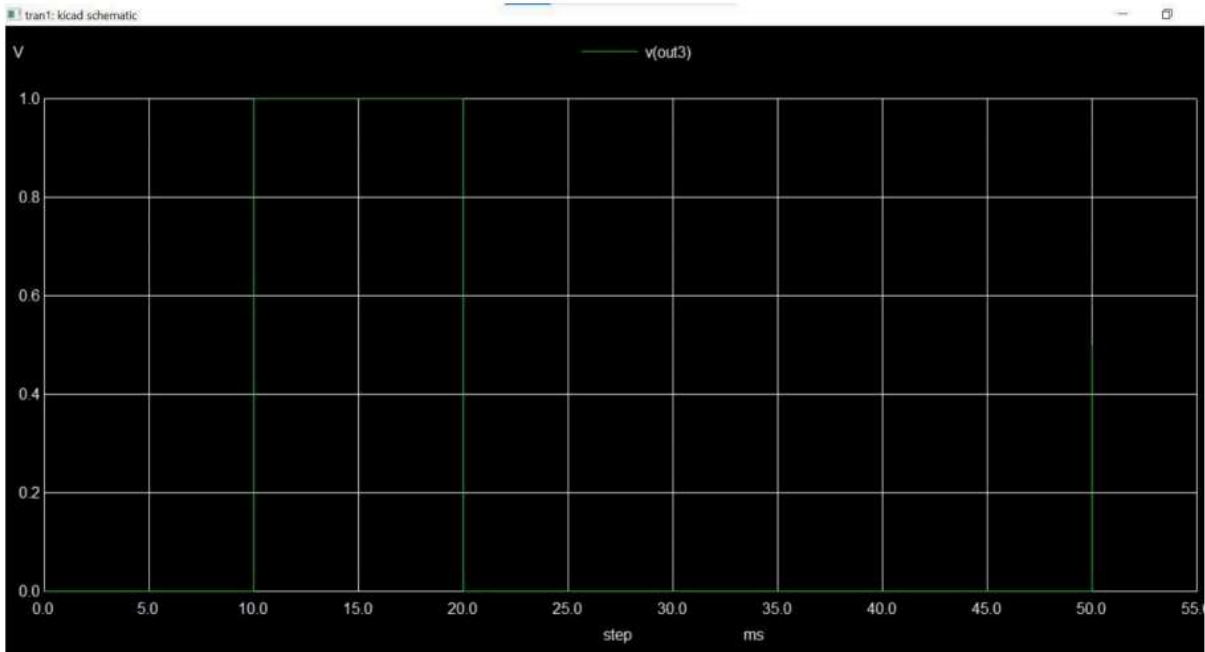

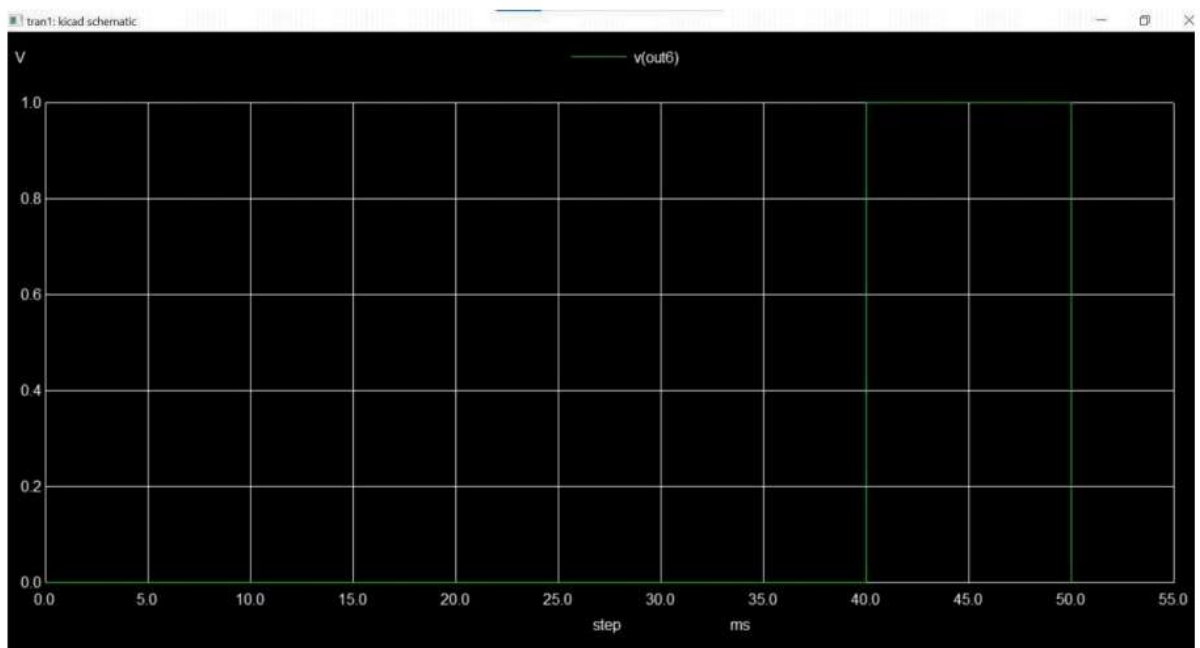
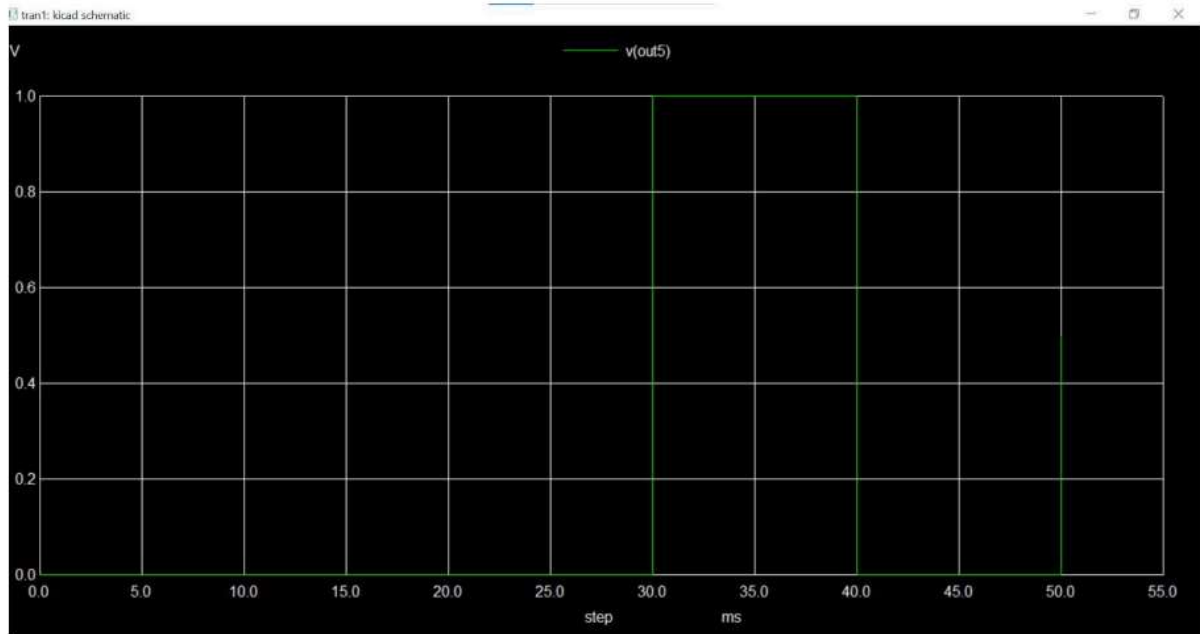

Research Paper/Journal/etc. :

Title: Design and Implementation of Digital Dice Using Decade Counter

Author: S. M. Mahajan, R. B. Patil

Page No.: 168–171

Link: <https://ieeexplore.ieee.org/document/9091979>

Source/Reference(s) :

CD4017 Decade Counter Datasheet, Texas Instruments.

Morris Mano, Digital Design, Pearson Education.