

# Analysis of Bistable Multivibrator Using Op-Amp

Sree Vishnu Varthini S

*Dept of Electronics and Communication Engineering  
Sri Eshwar College of Engineering, Coimbatore*

Dr. Maheswari Raja

*Dean Innovations  
Sri Eshwar College of Engineering, Coimbatore*

## Abstract

This paper explores the operational principles and applications of bistable multivibrators implemented using operational amplifiers (op-amps). Bistable multivibrators, commonly known as flip-flops, are fundamental components in digital electronics, crucial for storing binary information and controlling digital systems. The study delves into various configurations of bistable multivibrators utilizing op-amps, highlighting their advantages and limitations. The abstract discusses the significance of bistable multivibrators in digital systems, emphasizing their role in memory storage, sequential logic, and control applications. Additionally, it examines the practical implications of utilizing op-amps as comparators with positive feedback to achieve bistable behavior. Simulation of bistable multivibrator circuits using eSim software, with reference to previous simulations in Multisim, provides a hands-on approach to understanding their functionality and behavior. Overall, this paper contributes to a comprehensive understanding of bistable multivibrators and their practical applications in digital electronics, leveraging the capabilities of modern simulation tools for circuit analysis and design.

**Keywords:** Bistable Multivibrator, Op-Amp

## I. INTRODUCTION

A bistable multivibrator, often referred to as a flip-flop circuit, is a crucial component in digital electronics for storing binary information. When implemented using an operational amplifier (op-amp), it offers advantages of stability and reliability. The op-amp bistable multivibrator comprises two stable states, each capable of holding a binary value, typically represented as logic 0 or logic 1. In its simplest form, the op-amp bistable multivibrator utilizes positive feedback to latch into one of its stable states and remains there until triggered to switch. When a trigger signal is applied, the circuit toggles to the opposite state and holds that state until another trigger is received.

## II. PURPOSE OF BISTABLE MULTIVIBRATOR

The purpose of a bistable multivibrator, commonly known as a flip-flop, is to store binary information in digital systems. Specifically:

**Memory Storage:** Bistable multivibrators can store one bit of information, representing either a logic high or a logic low state. This makes them essential components for building memory elements in digital circuits.

**State Retention:** Once set to a particular state (either high or low), a bistable multivibrator maintains that state until it receives a trigger to change its state. This property enables the storage and retention of digital data.

**Clocking Signals:** In sequential logic circuits, bistable multivibrators serve as fundamental building blocks for generating and synchronizing clocking signals, facilitating the proper timing and sequencing of operations within the digital system.

## III. WORKING PRINCIPLE

A bistable multivibrator, employing an operational amplifier (op-amp), operates on the principle of positive feedback to achieve two stable output states. Initially, the op-amp is configured as a comparator with two inputs: non-inverting and inverting. The op-amp's output depends on the voltage difference between these inputs. When triggered, the input voltage exceeds a certain threshold, causing the op-amp's output to switch states due to positive feedback through a resistor network. This change in output state is retained even after the trigger is removed, as the positive feedback reinforces the new state. To revert to the initial state, another trigger must be applied, causing the op-amp's output to switch back. By utilizing this feedback mechanism, the bistable multivibrator circuit maintains stable binary states, making it essential for memory storage and control applications in digital systems.

#### IV. CIRCUIT DIAGRAM

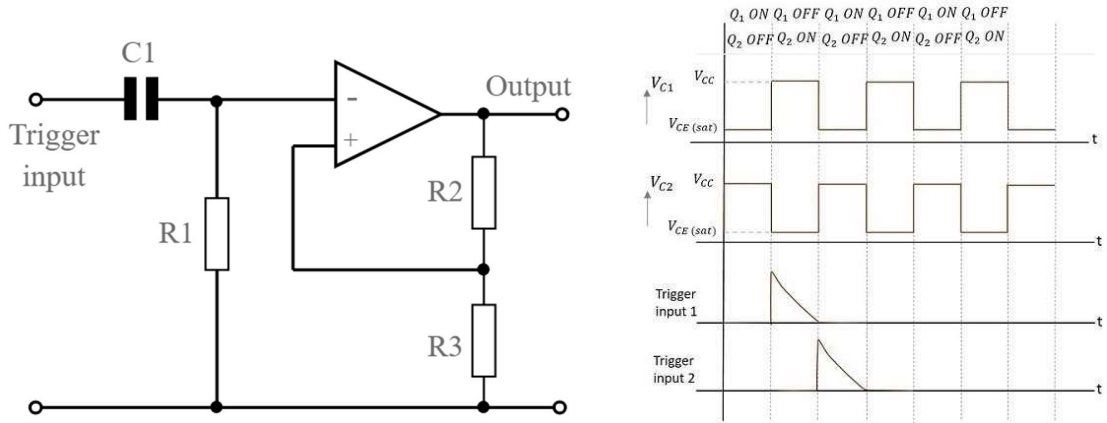

Fig. 1: Bistable multivibrator with sample output waveform

The circuit diagram of a bistable multivibrator using a single operational amplifier (op-amp) features the op-amp configured as a comparator with positive feedback. One input of the op-amp is connected to a voltage divider network, providing a reference voltage. The other input is connected to the output through a feedback resistor. This forms a regenerative feedback loop, allowing the circuit to exhibit two stable states. External trigger signals applied to the input can cause the op-amp to switch states, maintaining the selected state until another trigger is received.

#### V. EXISTING SYSTEM

The existing system incorporates a bistable multivibrator circuit implemented using Multisim software. The circuit is designed to demonstrate the functionality of a flip-flop, which is a fundamental building block in digital electronics. The bistable multivibrator, also known as a flip-flop, serves the purpose of storing binary information in digital systems.

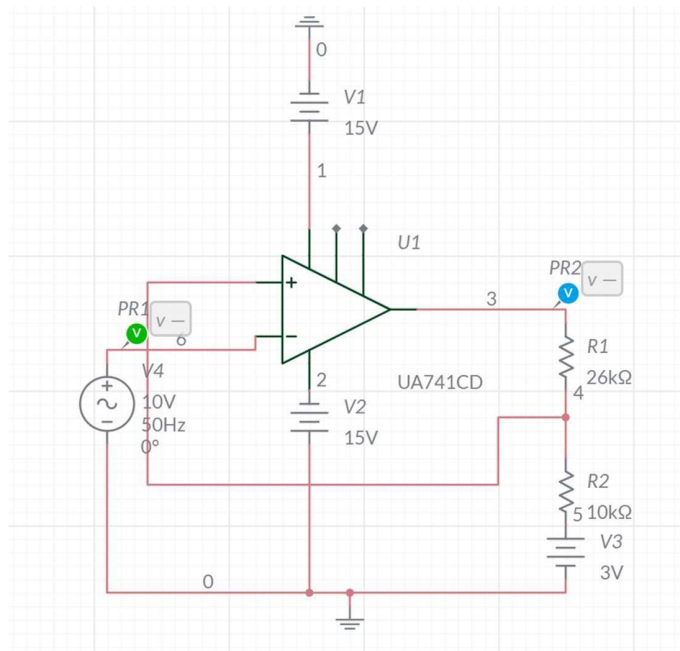

Fig. 2: Bistable multivibrator Circuit in Mutisim

Figure 2 illustrates a bistable multivibrator circuit designed within the Multisim software environment. The key components include an operational amplifier (op-amp) configured as a comparator, resistors forming a voltage divider network, and feedback resistors.

## OUTPUT WAVEFORM

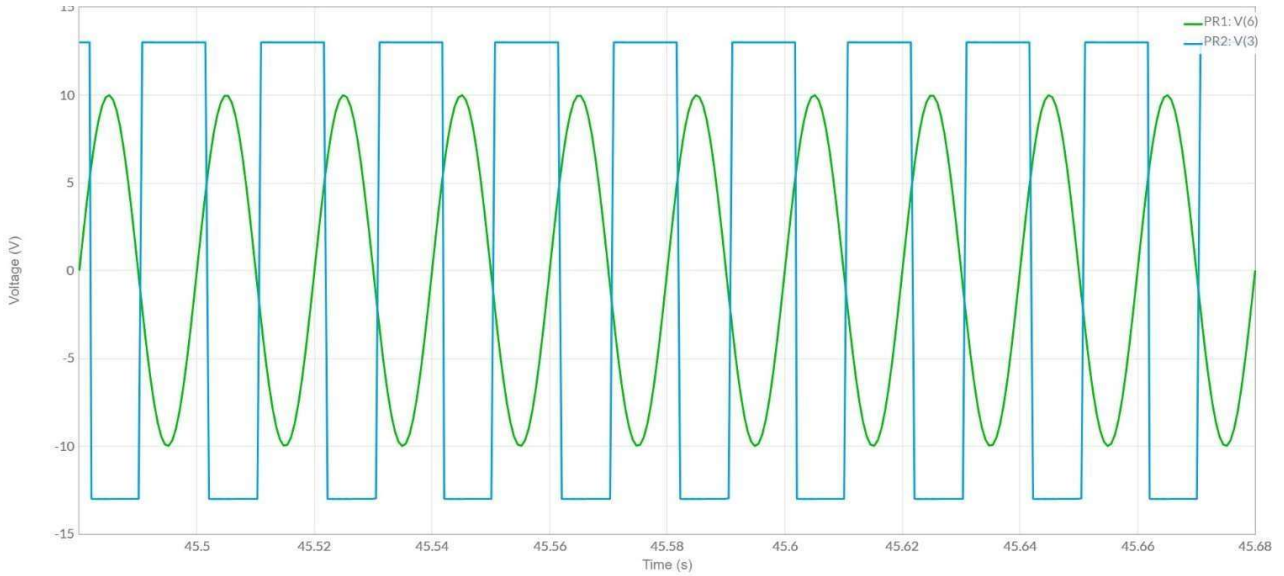

Fig. 3: Output Waveform of Bistable Multivibrator Circuit in Multisim

Figure 3 presents the output waveform of the bistable multivibrator circuit simulated in Multisim. The green waveform represents the trigger signal applied to the circuit, while the blue waveform denotes the corresponding output signal. The trigger signal initiates transition between the stable states of the bistable multivibrator, causing the output signal to switch accordingly.

## VI. PROPOSED SYSTEM

The proposed system introduces a bistable multivibrator circuit implemented using eSim software. This circuit aims to demonstrate the functionality of a flip-flop, a fundamental building block in digital electronics. The bistable multivibrator, also known as a flip-flop, serves the purpose of storing binary information in digital systems.

### eSIM CIRCUIT

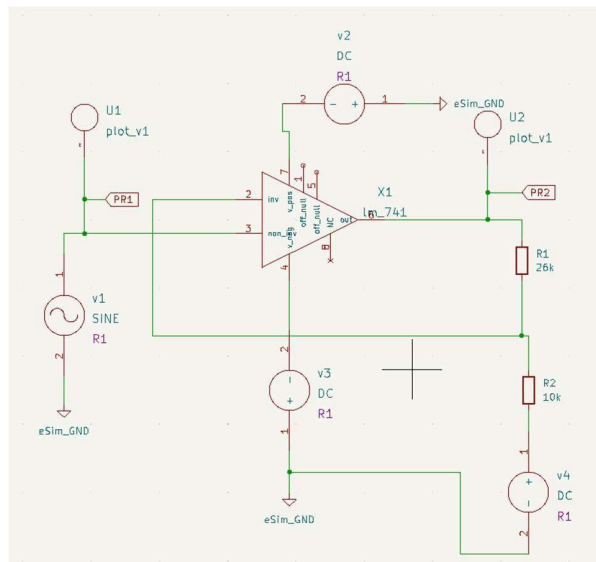

Fig. 4: Bistable multivibrator Circuit in eSim

Figure 3 presents the circuit diagram of a bistable multivibrator crafted within the eSim software environment. Key components include an operational amplifier (op-amp) configured as a comparator, resistors forming a voltage divider network, and feedback resistors. The op-amp's non-inverting input receives a reference voltage from the voltage divider, while its inverting input is linked to the output via a feedback resistor. This arrangement empowers the circuit to demonstrate bistable behavior, maintaining stable states in response to external triggers.

## OUTPUT WAVEFORM

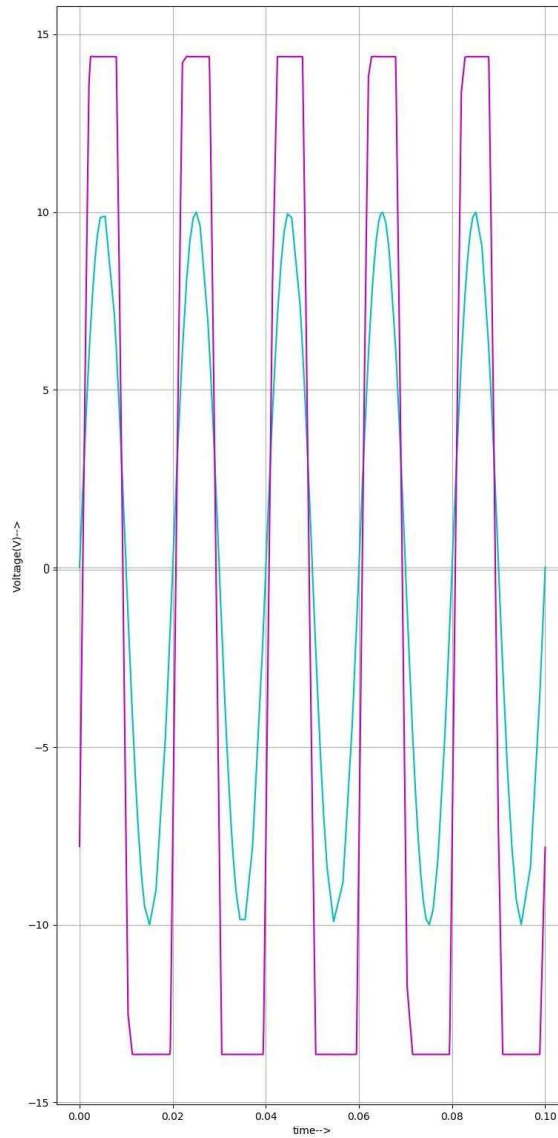

Fig. 5: Output Waveform Bistable multivibrator Circuit in Esim

Figure 5 showcases the output waveform of the bistable multivibrator circuit simulated using eSim software. The blue waveform represents the trigger signal applied to the circuit, while the pink waveform illustrates the corresponding output response. The trigger signal initiates a change in the circuit's state, prompting the output waveform to transition between its stable states.

## VII.

### CONCLUSION

In this study, we explored the design and simulation of a bistable multivibrator circuit using eSim. The bistable multivibrator, also known as a flip-flop, serves as a fundamental component in digital electronics, enabling the storage and retention of binary information. Through the simulation of the circuit, we have gained valuable insights into its functionality and behavior. Using eSim for simulation provided an interactive and intuitive platform for designing and analyzing electronic circuits. The software facilitated a comprehensive exploration of the bistable multivibrator's behavior, allowing for the study of its characteristics in both time and frequency domains. simplest design is basic source follower.

## REFERENCES

- [1] <https://www.multisim.com/content/kEuvLEJSd928r9LEJkn4Ab/op-amp-bistable-multivibrator-5074/open/>
- [2] <https://circuitdigest.com/electronic-circuits/bistable-multivibrator-circuit-using-op-amp>
- [3] I. TSVETKOVA AND A. BORODZHIEVA, "DESIGNING AND SIMULATION OF BISTABLE MULTIVIBRATORS WITH OPERATIONAL AMPLIFIERS IN MULTISIM," DOI: 10.1109/TELECOM53156.2021.9659685.
- [4] B. Carter and R. Mancini, *Op Amps for everyone*, 2017.
- [5] P. RAO, "PULSE AND DIGITAL CIRCUITS", TATA MCGRAW-HILL EDUCATION, 2006.