

Circuit Simulation Project

<https://esim.fossee.in/circuit-simulation-project>



Name of the participant : Priyash Sharma

Affiliation / Institution : The School of Computing Science and Engineering (SCOPE), VIT Bhopal University, Sehore, Madhya Pradesh, India

Title of the circuit : Circuit-Level Smart Parking Monitoring System Using CD4017-Based Sequential Scanning

Theory/Description : This circuit simulates a sequential smart parking monitoring system entirely at the hardware level, bypassing the need for a microcontroller. The architecture consists of three primary stages:

1. **Clock Generation:** An LM555 Timer IC configured in astable mode acts as the system's heartbeat, generating continuous square-wave clock pulses.
2. **Sequential Scanning:** A CD4017 CMOS decade counter receives these clock pulses. With each pulse, it sequentially drives its output pins (Q0 to Q9) HIGH, effectively scanning an array of parking slots one by one.
3. **Sensor Simulation & Digitization:** Physical parking slots are modeled using a matrix of voltage dividers and one-way 1N4148 isolation diodes. An "Empty" slot is simulated using a 10k Ω / 1k Ω divider (dropping the output voltage to a logic LOW), while an "Occupied" slot uses a 1k Ω / 10k Ω divider (passing a higher voltage as a logic HIGH). All slot outputs are multiplexed onto a single common bus. An LM393 dual differential comparator evaluates this multiplexed bus against a fixed reference voltage, outputting a clean, digitized serial waveform representing the real-time occupancy status of the parking array.

Reason to simulate with eSim : eSim was chosen for this project to test a proof-of-concept for mixed-signal sequential logic. Simulating this circuit allows for the precise analysis of analog-to-digital interfacing challenges—specifically, observing how continuous clock pulses interact with discrete logic counters. Furthermore, eSim's transient analysis capabilities are crucial for verifying the dynamic responsiveness of the diode-multiplexed sensor matrix and observing real-world physics, such as "floating bus" voltage trapping and component aliasing, before moving to physical hardware prototyping.

Expected Outcome/outputs : *(Describe what is expected when the circuit is simulated or implemented. Explain the working behavior, measurable outputs, and how the circuit performance can be validated.)

Circuit Diagram(s) : The circuit is expected to generate a repeating, digitized serial waveform

that accurately maps the physical configuration of the parking slot matrix. When the CD4017 scans an occupied slot, the output waveform will generate a distinct logic HIGH pulse. When scanning an empty slot, the waveform will drop to a logic LOW. The system will successfully reset and repeat the sequence upon completing the full slot scan.

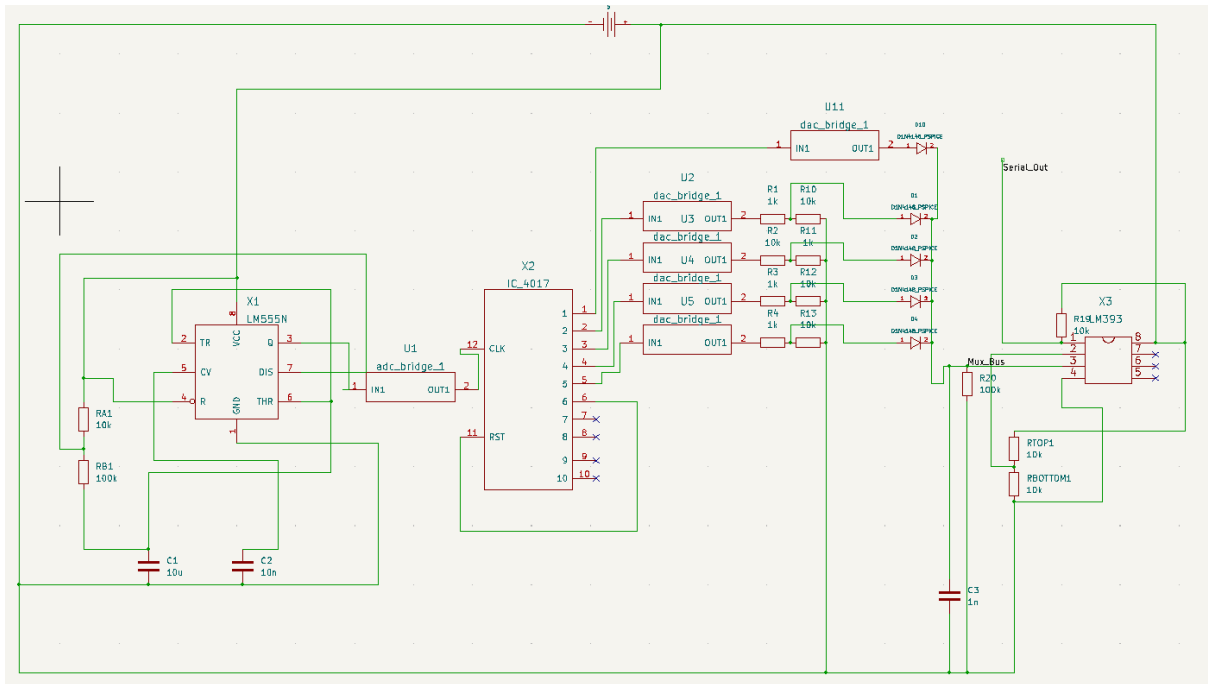

Figure 1 Circuit Diagram

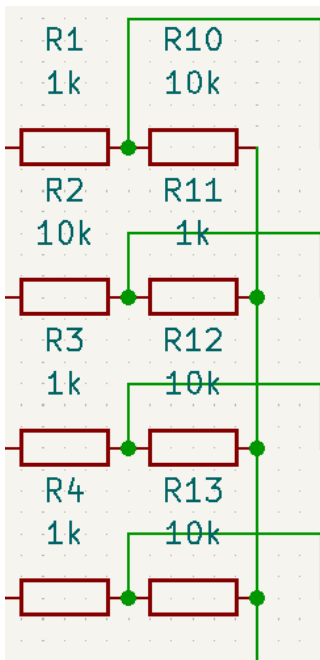

Figure 2 Figure A - Sensor matrix configured for 3 occupied slots (1k/10k) and 1 empty slot (10k/1k).

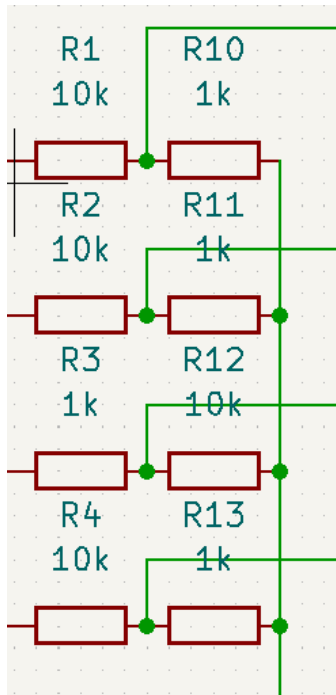

Figure 3 Figure B - Sensor matrix configured for 1 occupied slot and 3 empty slots.

Expected Results (Input, Output waveforms and/or Multimeter readings) :

Upon running a transient analysis (e.g., with a 13ms timestep to prevent aliasing), the serial output node (/serial_out) will output a square wave whose amplitude depends on the slot status.

- For Occupied Slots, the waveform will peak at approximately ~6.8V (Logic HIGH).
- For Empty Slots, the waveform will rest at approximately ~1.5V to 2.0V (Logic LOW).
- The sequence length and logic pattern (e.g., High-Low-High-High) will perfectly mirror the physical arrangement of the 1kΩ and 10kΩ resistors in the sensor matrix.

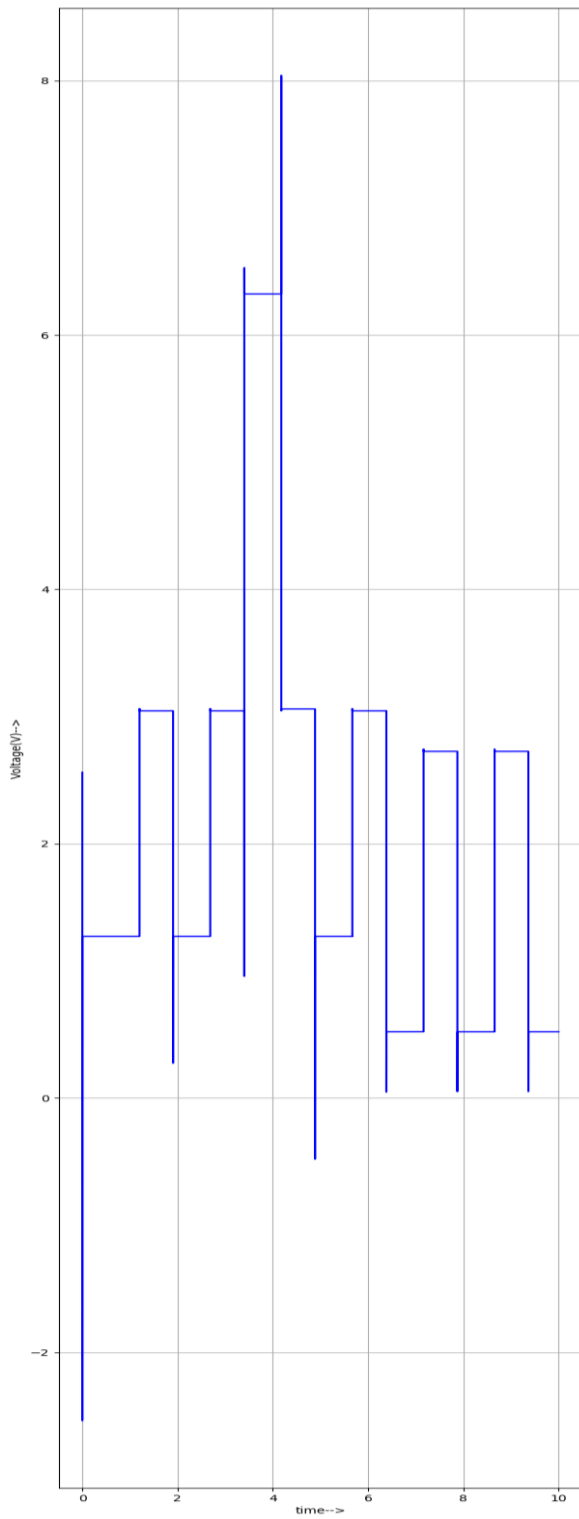

Figure 5 Output waveform for Configuration B, successfully generating a LOW-LOW-HIGH-LOW serial data stream.

Research Paper/Journal/etc. :

Research Paper/Journal/etc. : Title : The Smart Parking System Using Ultrasonic Control Sensors

Author : Yousif Allbadi, Jinan N. Shehab, Musaab M. Jasim

Page No.: 012064

Link : <https://doi.org/10.1088/1757-899X/1076/1/012064>

Source/Reference(s) :

1 FOSSEE eSim User Manual and NGspice Documentation.

Link: <https://esim.fossee.in/resources> **Link:** <https://ngspice.sourceforge.io/docs/ngspice-manual.pdf>

2 Texas Instruments CD4017B CMOS Counter Datasheet.

Link: <https://www.ti.com/product/CD4017B>

3 Texas Instruments LM555 Timer Datasheet.

Link: <https://www.ti.com/product/LM555>

4 Texas Instruments LM393 Dual Differential Comparator Datasheet.

Link: <https://www.ti.com/product/LM393>
