

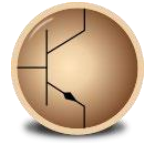

VIT[®]
Vellore Institute of Technology
(Deemed to be University under section 3 of UGC Act, 1956)
CHENNAI



Circuit Simulation Project

<https://esim.fossee.in/circuit-simulation-project>

Name of Participant: Sreenath S

Project Guide: Dr. Maheswari. R

Title: Half Subtractor Using NOR Gate

Introduction:

The half Subtractor is a combinational circuit used to subtract two bits from an input with two output states namely 'difference' and 'borrow'. The digital circuits can be designed with the help of logic gates which is an electronic circuit which performs logical operations based upon their inputs and gives the output in the form of only a single bit, either low or high. NOR gate is a universal gate because of which we can design any type of digital circuit with using of n number combinations of NOR gates. They have various uses like minimization of distortions in the sound, in amplifiers and also in the ALU (Arithmetic Logic Unit).

Block Diagram

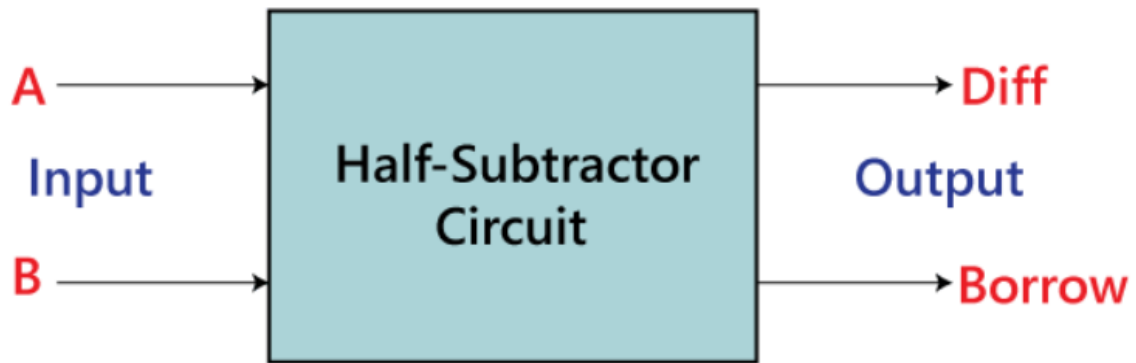

Truth Table

Inputs		Outputs	
A	B	Diff	Borrow
0	0	0	0
0	1	1	1
1	0	1	0
1	1	0	0

The SOP form of the **Difference** and **Borrow** is as follows:

$$\text{Difference} = A'B + AB'$$

$$\text{Borrow} = A'B$$

K Map for Difference and Borrow

The Half Subtractor has 2 inputs A and B. From the truth table, the minterms can be obtained for each output. The minterms are plotted in the Karnaugh map and the simplified Boolean expressions are obtained.

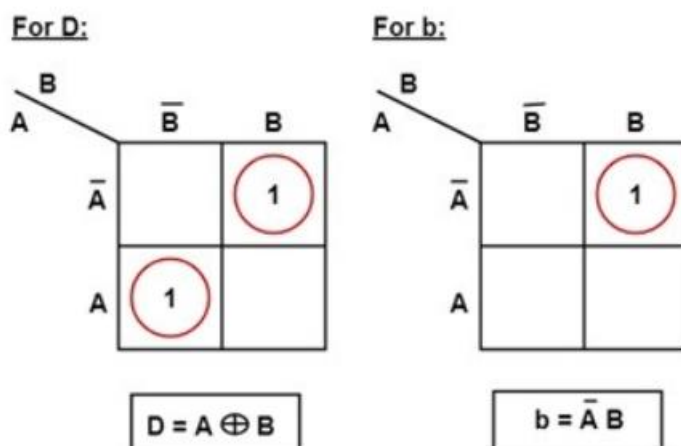

Implementation of Half Subtractor using NOR Gate

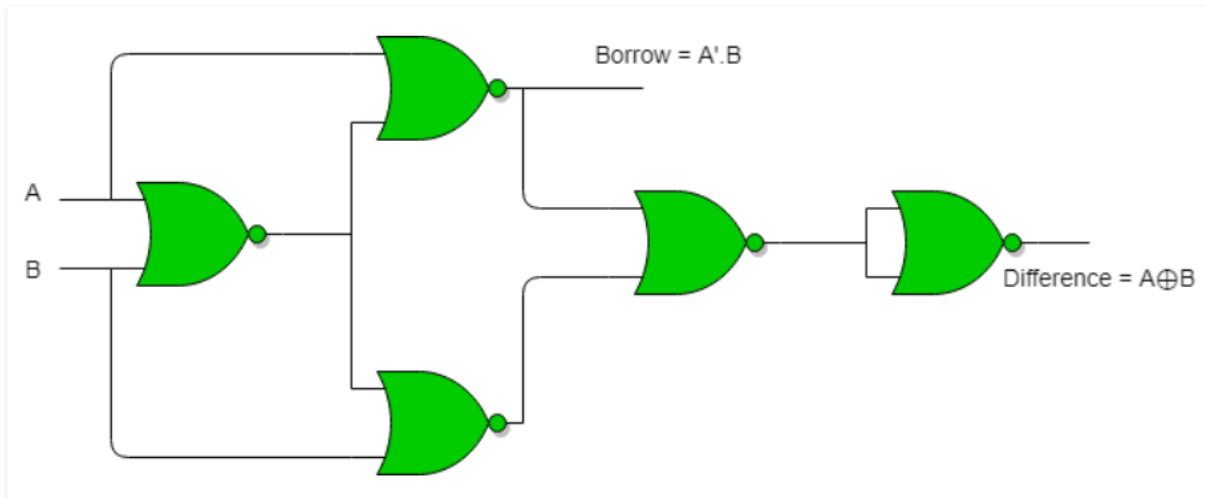

Schematic Diagram:

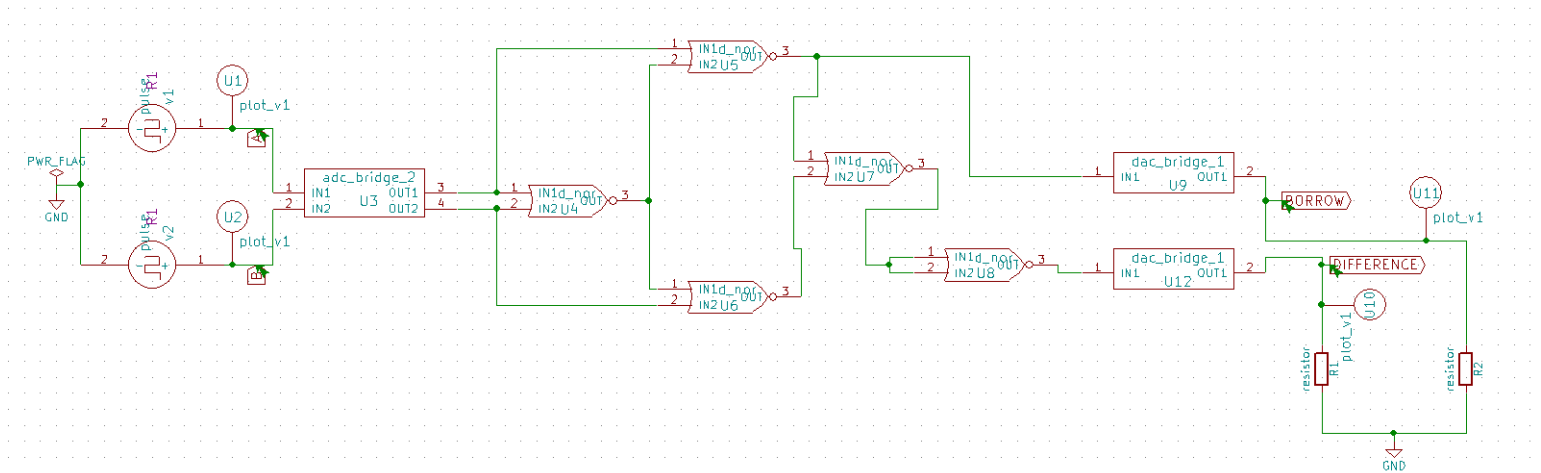
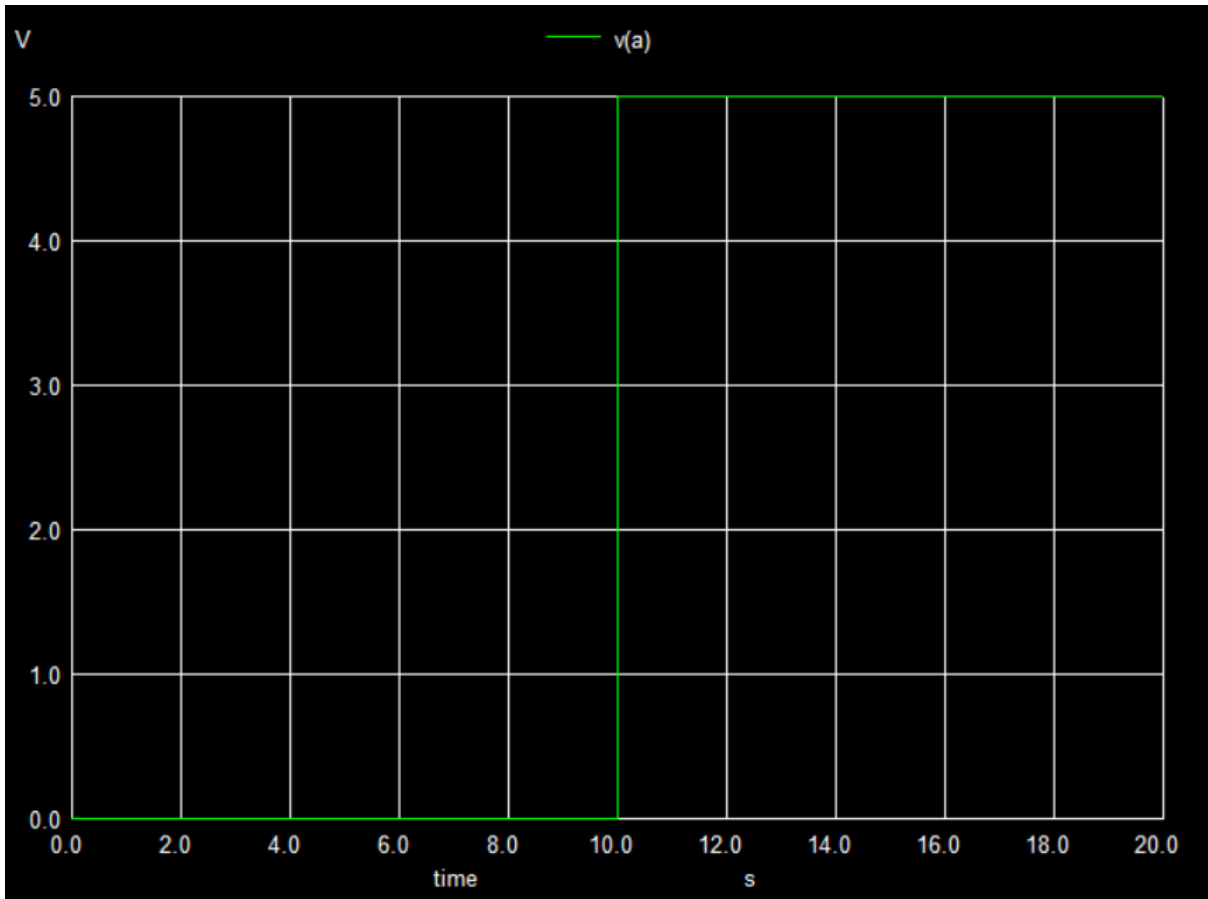
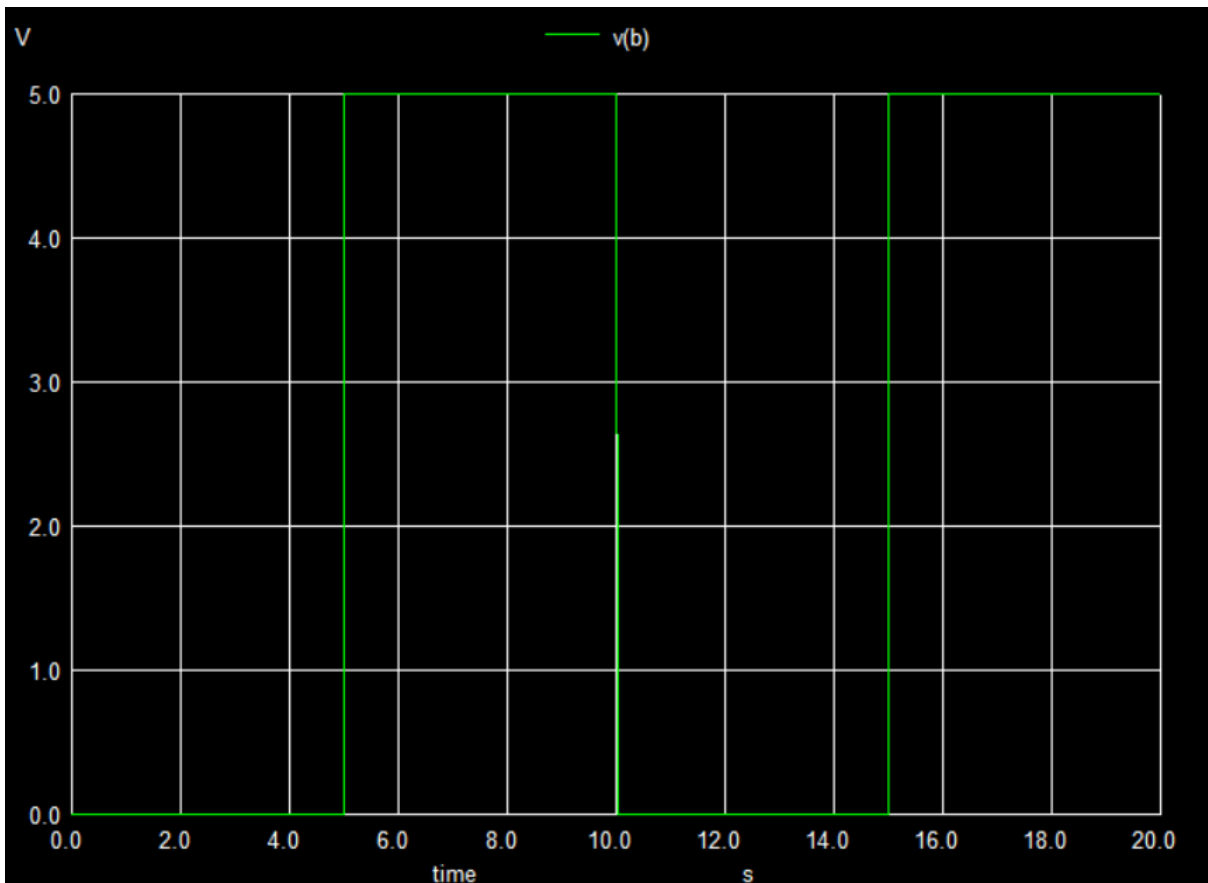

Fig.1. Half Subtractor Using NOR Gates schematic diagram

NGSPICE Output Waveform at A:



NGSPICE Output Waveform at B:



NGSPICE Output Waveform at Difference:

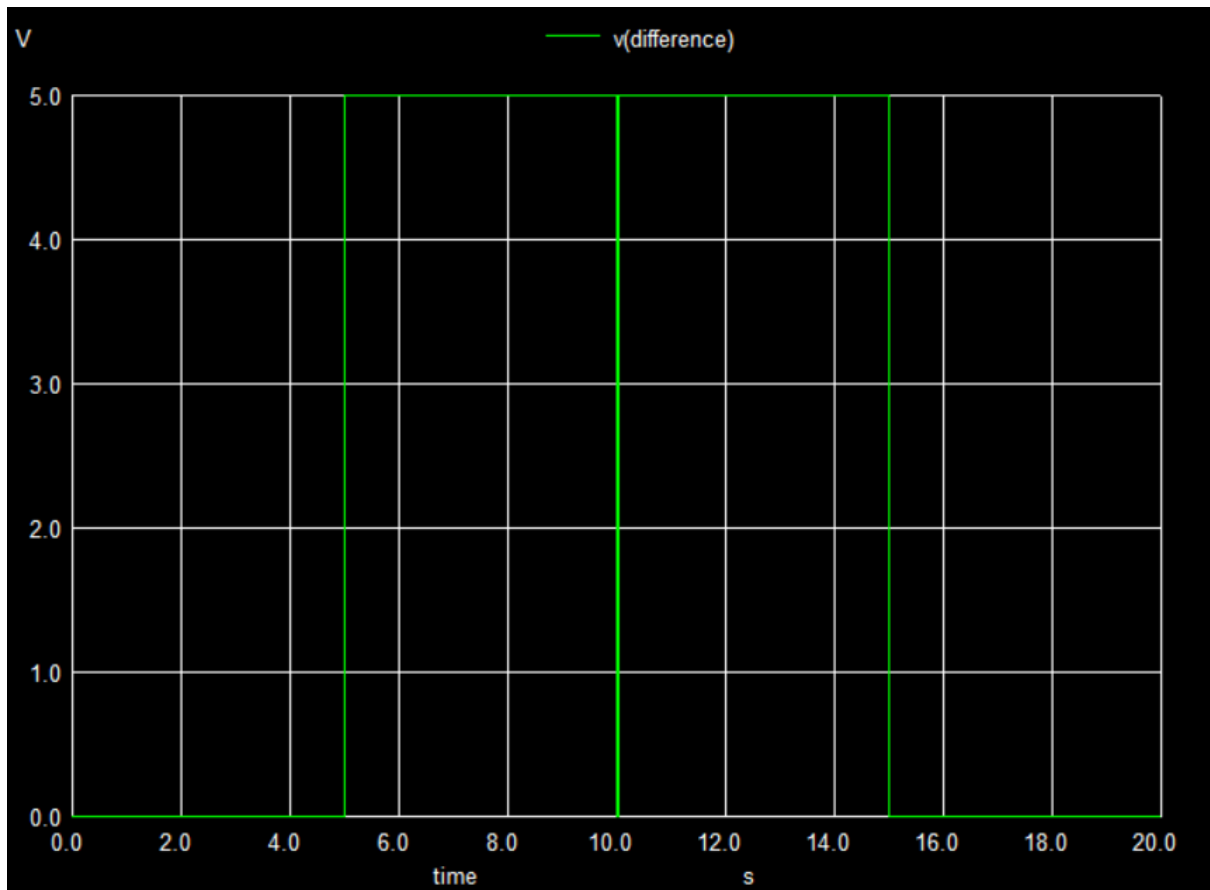

NGSPICE Output Waveform at Borrow:

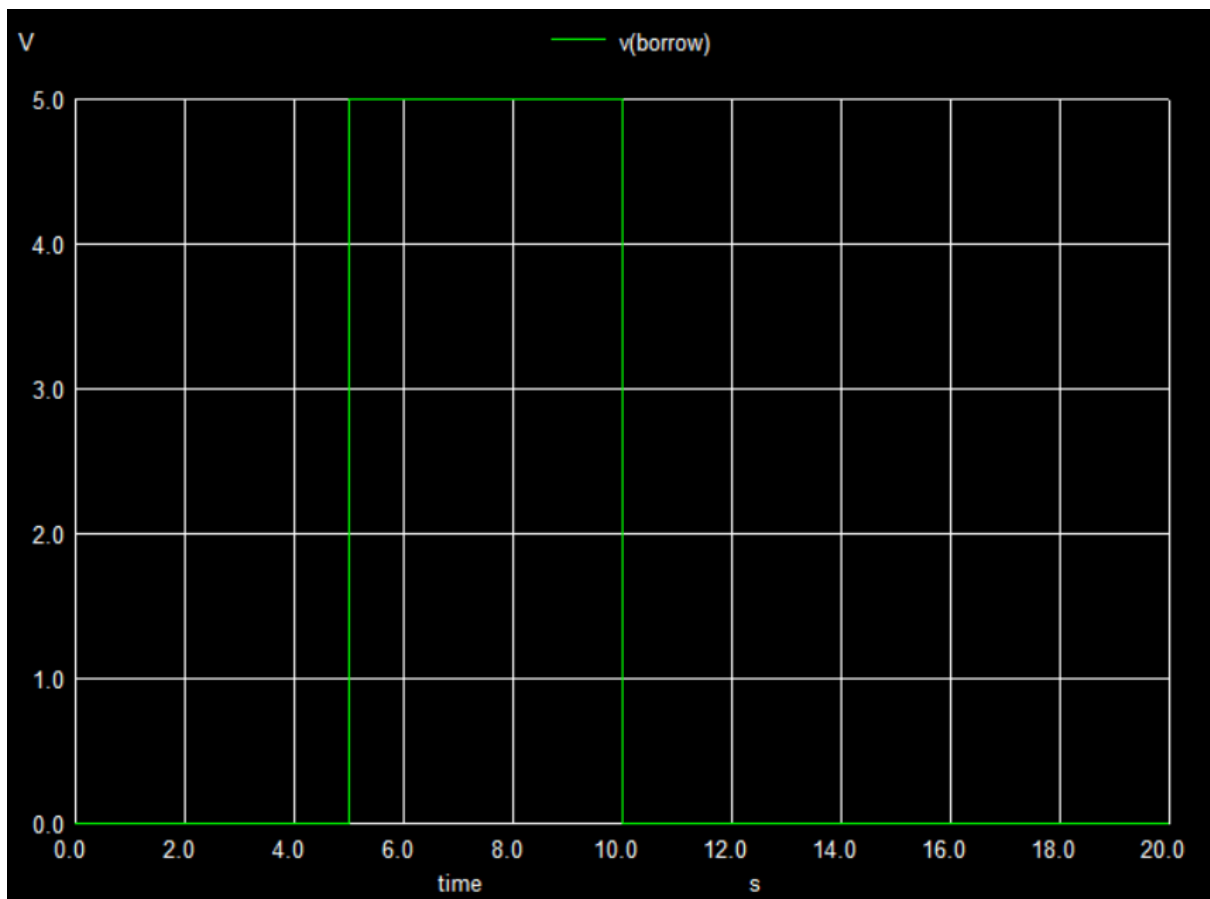

Python Plot at A

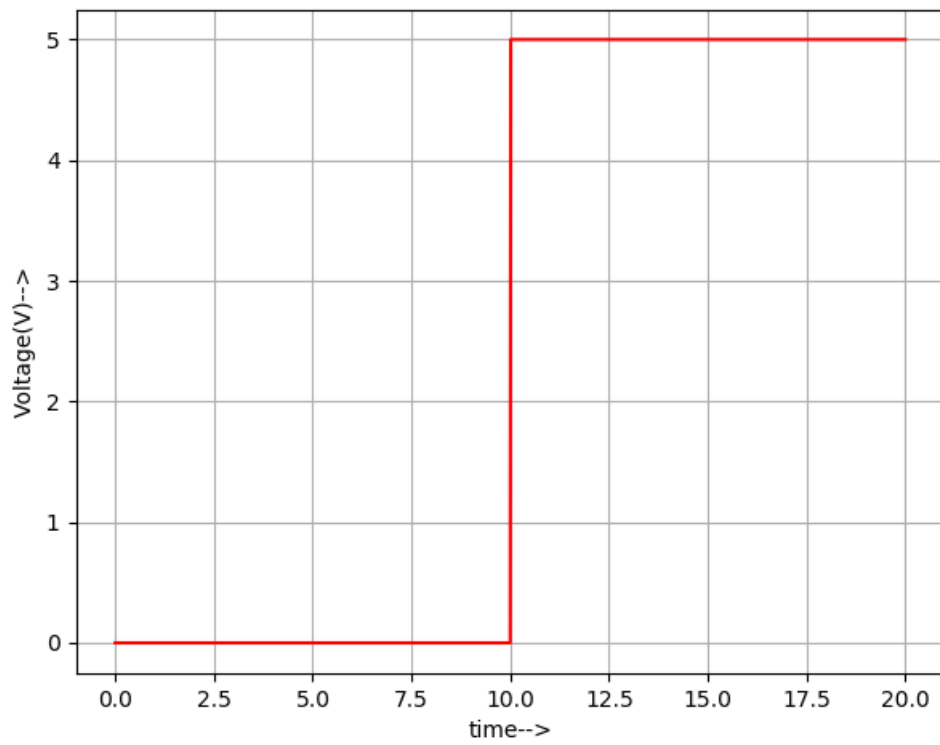

Python Plot at B

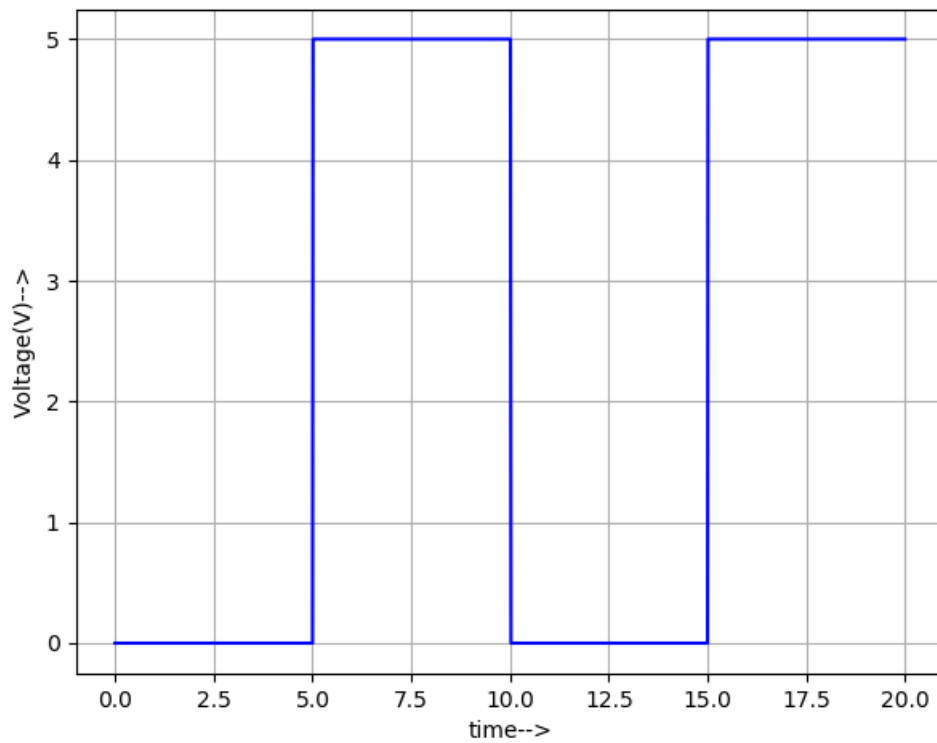

Python Plot at Difference

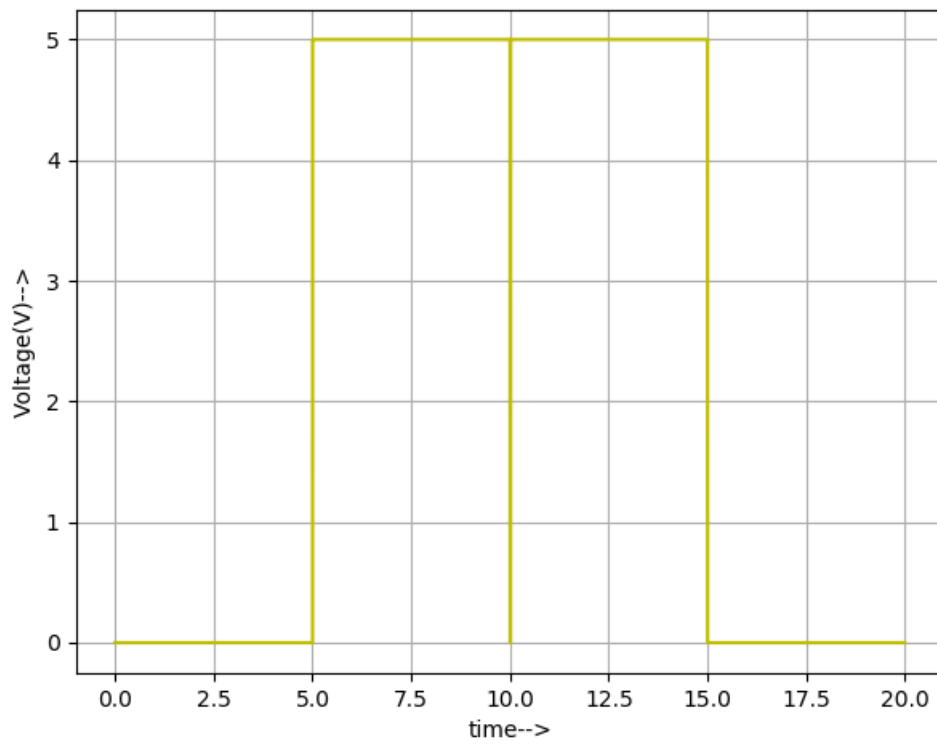

Python Plot at Borrow

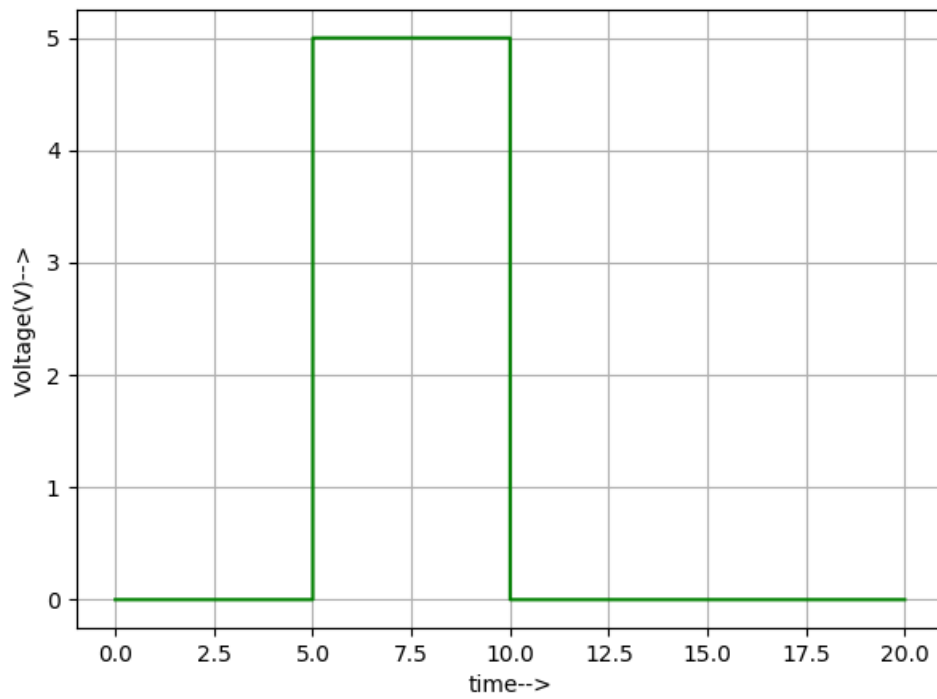

Reference:

- <https://www.geeksforgeeks.org/half-adder-half-subtractor-using-nand-nor-gates/>

Conclusion:

Thus Half Subtractor was designed with NOR Gates and output waveform obtained successfully using eSIM software.